



# Titan Battery User Manual



SCAN QR CODE

For More Details

# TABLE OF CONTENTS

<b>1.Overview</b>	<b>3</b>
1.1 Scope	3
1.2 Intended Audience	3
1.3 Manual Usage	3
<b>2.Introduction</b>	<b>3</b>
<b>3.Safety Instructions</b>	<b>4</b>
3.1 Labeling Explanation	4
3.2 Installation Tools	4
<b>4.Precautions</b>	<b>5</b>
4.1 Manual Storage	5
4.2 Label Protection	5
4.3 Safety Warning Labels	5
4.4 Personnel Requirements	5
4.5 Power-On Measurement	6
4.6 Measuring Instruments	6
4.7 Maintenance And Inspection	6
<b>5.Overview Of Main Components</b>	<b>7</b>
5.1 Product Configuration List	7
<b>6.Product Introduction</b>	<b>7</b>
6.1 Overview	7
6.2 Advantages	8
<b>7.Product Appearance</b>	<b>8</b>
7.1 Product Model	8
7.2 Control Panel	9
7.3 Port Panel	10
<b>8.Principle And Structure</b>	<b>11</b>
8.1 Operating Principle	11
8.2 Connection Structure	11
<b>9.Battery Installation And Wiring</b>	<b>12</b>
9.1 Tool Preparation For Installation	12
9.2 Installation Preparation	12
9.3 Installation Notes	12
9.4 Installation Steps	12
9.5 Electrical Connection	14
<b>10.Debugging</b>	<b>16</b>
10.1 RS485 &CAN Port Definition	16

**11.Upper Computer Software Operation Guide- - - - - 17**  
11.1 Tools - - - - - 17  
11.2 Operating Steps - - - - - 17  
**12.ADS Dip Switch Definitions - - - - - 20**  
**13.Battery Parallel Connection Dip Switch Diagram- - - - - 21**  
**14.Power-on Sequence - - - - - 22**  
**15.Common Issues And Solutions - - - - - 22**  
**16.Inverter Matching Information- - - - - 23**  
**17.Maintenance - - - - - 24**

# 1.Overview

## 1.1 Scope

This user manual provides information, instructions and maintenance guidelines for the low-voltage household energy storage battery series. The Residential energy storage series is a lithium battery system developed to be compatible with various inverter brands on the market.

## 1.2 Intended Audience

This manual is intended for professional technical personnel involved in the installation, operation, and maintenance of lithium batteries, as well as end-users seeking technical information.

## 1.3 Manual Usage

1. Before using the product, carefully review this user manual and keep it in a readily accessible location.
2. All information in this user manual, including images and symbols, is owned by our company, and the use of any part or all of this manual by individuals outside the Company is strictly prohibited without authorization.



# 2.Introduction

1. The residential energy storage series is a battery module developed by for low-voltage lithium battery systems, primarily applied in the field of residential energy storage. It can achieve high-precision multi-cell voltage and temperature acquisition.
2. The module adopts a passive balancing method, with a maximum balancing current of up to 300mA, improving the overall lifespan of the battery pack.
3. The module features external communication interfaces using CAN, RS485, and dry contact communication methods, allowing communication in parallel for up to 16 batteries.
4. Embedded BMS system effectively monitors phenomena such as over-temperature, over-voltage, and over-current, reducing the risk of battery damage or even fire, ensuring the safety of life and property.
5. This manual introduces the types, sizes, performance, technical characteristics, warnings, and precautions of lithium battery systems. This specification applies only to battery systems supplied by the Company.

## 3. Safety Instructions













### 3.1 Labeling Explanation

To ensure user safety during product use, relevant labeling information with appropriate symbols is provided in this manual. The following lists symbols that may be used in this manual, so please read carefully.

Icon	Description
	Signifies a low-level potential hazard. Failure to avoid may result in minor or moderate injury to personnel.
	Indicates the presence of high voltage inside the battery module. Touching may lead to electric shock hazards.
	Wear suitable protective gears (clothing, shoes and gloves) to prevent electrostatic damage on the equipment.

### 3.2 Installation Tools

Prior to installation, prepare the following tools:

Category	Description		
General Tools	 Multimeter	 Protective gloves	 Insulated safety shoes
	 Protective clothing	 Safety goggles	 Antistatic wrist strap
Installation Tools	 Electric screwdriver	 Socket wrench	 Wire stripper
	 Phillips screwdriver (M4/M6)	 Electric drill	 Hammer

## 4. Precautions

### 4.1 Manual Storage

1. This manual covers crucial information for the Home Energy Storage Series. Prior to operating the product, carefully read this manual as it provides essential assistance in acquainting you with the product.
2. Store this manual securely for the convenience of relevant installation and maintenance personnel to refer to during operations.
3. Strictly follow the descriptions in this manual when operating the Home Energy Storage Series to avoid equipment damage, injuries, property loss, and other potential issues.

### 4.2 Label Protection

1. Warning labels on the Home Energy Storage Series contain crucial safety operation information. It is strictly prohibited to intentionally tear or damage them!
2. The product has a nameplate on the casing, providing essential parameter information. It is strictly prohibited to intentionally tear or damage it!

### 4.3 Safety Warning Labels

When conducting installation, routine maintenance, inspections, etc., on the Home Energy Storage Series, to prevent unauthorized individuals from approaching, engaging in improper operations, or accidents, adhere to the following conventions:

1. Erect clear signage at the switch locations of the products to prevent accidents caused by accidental closing.
2. Set warning signs or establish safety warning tape near the operating area to prevent unrelated personnel from approaching.
3. After maintenance or inspection, conduct a thorough on-site safety check.

### 4.4 Personnel Requirements

1. Only personnel with relevant professional qualifications are allowed to perform various operations on this product.
2. Operating personnel should be thoroughly familiar with the composition and working principles of the entire Home Energy Storage Series system.
3. Operating personnel should be fully acquainted with the "User Manual" for this product.

## 4.5 Power-On Measurement



### Danger

After the energy storage battery is installed, there is a high voltage present, and accidental contact with the positive and negative terminals may result in electric shock injuries. Therefore, when conducting power-on measurements, attention should be paid to the following:

1. Take necessary insulation protection measures (such as wearing insulated gloves).
2. Accompanying personnel must be present to ensure personal safety.

## 4.6 Measuring Instruments



### Danger

When performing electrical connections and trial operations on the energy storage backup battery, and to ensure that electrical parameters meet requirements, relevant electrical measuring equipment such as multimeters, power meters, etc., should be used. Note the following:

1. Use measuring equipment with a suitable range that conforms to on-site working conditions.
2. Ensure the correct and standardized electrical connections of the instruments to avoid dangers such as electric arcs.

## 4.7 Maintenance And Inspection



### Danger





When both the energy storage battery and the inverter are turned off, and electrical connections are confirmed to be disconnected, maintenance or inspection operations can be carried out on the energy storage battery cabinet. Pay attention to the following:

1. Ensure that the energy storage battery will not be accidentally re-energized.
2. Use a multimeter to ensure that the energy storage battery is completely de-energized.
3. For parts near potentially live components during operations, use insulating materials for insulation covering or grounding.
4. It is strictly prohibited to perform maintenance or inspection operations on live equipment!

When performing maintenance or inspection on equipment, it must be ensured that at least two personnel are present at the site, Maintenance operations can only be carried out after the equipment is safely de-energized, fully charged, or discharged.

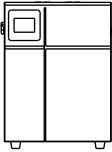
## 5. Overview of Main Components

### 5.1 Product Configuration List

No.	Image	Name	Qty
1		Battery	1
2		Expansion Bolt	4
3		Communication Cable	1
4		Battery Wire (red)	1
5		Battery Wire (black)	1

The product configuration list is subject to change without prior notice.

## 6. Product Introduction

### 6.1 Overview

The household energy storage series lithium battery module integrates high-capacity, high-safety lithium iron phosphate battery cells. It adopts a stacked design with advantages in footprint and vertical space utilization. The module incorporates a high-precision Battery Management System (BMS) unit, monitoring and collecting real-time data on voltage and temperature inside the module. This enables intelligent temperature control at the cell level and smart cell balancing, enhancing system efficiency and battery cycle life. The module features a shock-resistant structure within a cold-rolled sheet metal shell for high safety and reliability, meeting household standards. Additionally, the module is designed for high stability and disturbance resistance, ensuring the safe and reliable operation of the battery system.

## 6.2 Advantages

- 1.The positive electrode material of the battery is lithium iron phosphate (LiFePO4) material, which has good safety performance, has a cycle life of more than 6,000 times.
- 2.The high-performance intelligent management system is adopted to realize comprehensive state control of battery charging, discharging, floating charging and hibernation, and multi-level protection is set for voltage, current, temperature, etc., so that the battery is always in an ideal state.
- 3.It has a comprehensive monitoring system to monitor the voltage, current, temperature, capacity and working status of the battery.
- 4.The system adopts an intelligent design method to meet the four remote control standards of the national standard: telemetry, remote signaling, remote control, and remote adjustment.
- 5.Built-in intelligent balance module to ensure the capacity consistency of the battery pack during long-term use and prolong the service life.
- 6.The control panel includes status display and alarm devices, which can visually see the working status and alarm information of the battery.
- 7.The system has its own intelligent thermal management device, which can work in a wide temperature range.

## 7.Product Appearance

### 7.1 Product Model

The technical parameters of LiFePO4 Battery Energy Storage System are shown in Table 1 below:

Items	25.6V 100Ah	51.2V 100Ah	51.2V 300Ah
Energy Storage	2560Wh	5120Wh	15360Wh
Rated Voltage	25.6V	51.2V	51.2V
Voltage Range	21.6V-29.2V	43.2V-58.4V	43.2V-58.4V
Max Charge Current	100A	100A	200A
Max Discharge current	100A	100A	200A
Discharging Cut-off Voltage	21.6V	43.2V	43.2V
Floating Voltage	28.8V	57.6V	57.6V
Cycle life	6000 cycles @ 80% DOD		
Work Temperature	-20°C~55°C		

## 7.2 Control Panel

The control panel structure of LiFePO4 battery energy storage system is shown below:

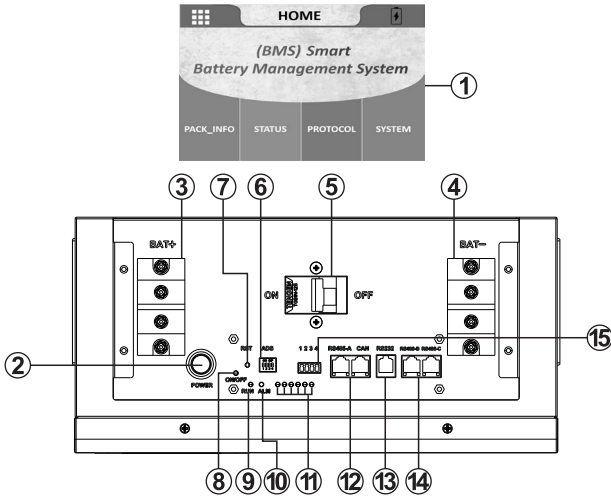

The BMS of 100A is shown in the figure above

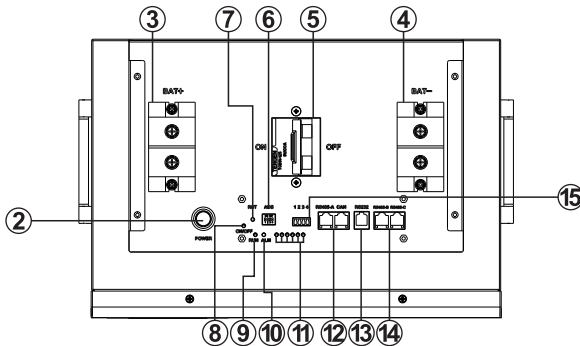

The BMS of 200A is shown in the figure above

- |                        |                             |
|------------------------|-----------------------------|
| 1. LCD display         | 9.Operation light(RUN)      |
| 2. Power on/off switch | 10.Alarm light(ALM)         |
| 3. Positive terminal   | 11.Capacity light(capacity) |
| 4. Negative terminal   | 12.RS485A&CAN               |
| 5.Air circuit breaker  | 13.RS232                    |
| 6.ADS dip switch       | 14.RS485B&RS485C            |
| 7.RST button           | 15.Dry contact              |
| 8.Power ON/OFF light   |                             |

Remark: The LiFePO4 battery energy storage system is divided into wall mounted and vertical cabinet, the panel position is the same, and the LCD in the battery pack is different but the function is the same.

### 7.3Port Panel

No.	Name	Function	Notes
1	Power on/off switch	Battery power switch button	
2	LCD display	Key LCD display/ Touch Display	
3	Function buttons	Battery Function buttons	
4	Positive and negative terminal	Battery Positive Output / Battery Negative Output	
5	Air circuit breaker	Circuit On/Off Control	Failure Protection
6	ADS dip switch	(Please refer to Form 13.ADS Dip Switch Definitions for details)	
7	RST button	Battery Reset	Briefly tap and release within 1-3 seconds.
8	Power ON/OFF light	Battery Start Indicator Light	
9	Operation light(RUN)	Battery Operation Indicator Light	
10	Alarm light(ALM)	Battery Alarm Indicator Light	
11	Capacity light(CAPACITY)	Battery Capacity Indicator Light	
12	RS485A&CAN	485 Communication Interface CAN Communication Interface	Communication with inverter via RS485 Communication with inverter via CAN
13	RS232	1. Monitor batteries and modify parameters. 2. Perfm software upgrades.	
14	RS485B&RS485C	Communication between batteries	Functions are the same, no distinction between left and right.
15	Dry contact	Dry Contact Communication	1. Dry Contact 1 - PIN1 to PIN2: Normally open, closed during fault protection; 2. Dry Contact 2 - PIN3 to PIN4: Normally open, closed during low battery alarm.
16	Ground terminal port	Battery Ground	

## 8.Principle And Structure

### 8.1 Operating Principle

Working principle for Residential LiFePO4 Battery Energy Storage System: Connect battery pack in parallel to the DC output end of the inverter of the energy storage device. When the mains power supply is normal, the inverter module works normally to supply power to the equipment(the load in the figure) and charge the battery pack; when the utility power and photovoltaic power are cut off, the battery pack provides uninterrupted power supply to the inverter to ensure the normal operation of household electricity: When power is turned on again, the battery pack is charged while power is restored to the household loads.

### 8.2 Connection Structure

The connection diagram of residential LiFePO4 battery energy storage system is shown in Figure 1 below:

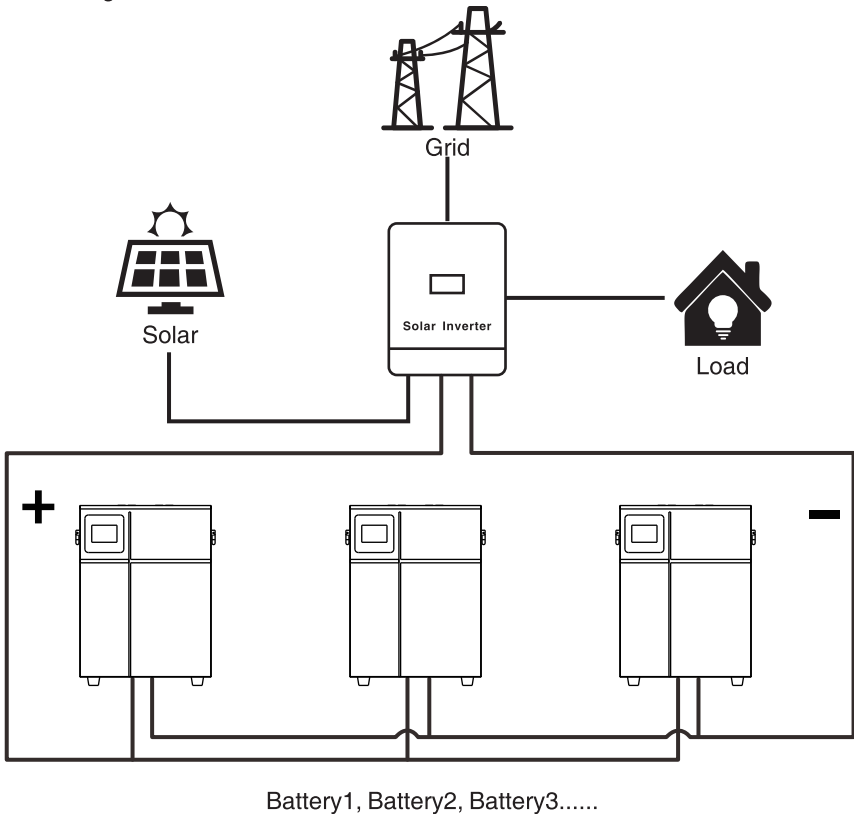

**Figure 1 Operation Principle Diagram of Battery System**

## 9. Battery Installation And Wiring

### 9.1 Tool Preparation For Installation

Tools Required: Electric drill, hammer, wrench, M8\*60 expansion bolt, Phillips screw-driver, multimeter, insulated gloves, Ethernet cable, power cable.

### 9.2 Installation Preparation

#### Safety Regulations

The installation, operation and maintenance of LiFePO4 Battery Energy Storage System should only be carried out by trained and qualified professionals. Before installation and use, please read the safety precautions and related operating procedures of this product carefully. The installation process must strictly abide by the following safety regulations and local safety regulations, otherwise it may cause personal injury or product damage.

1. Please ensure that the inverter connected to the battery is a qualified power system;
2. When installing the battery, please ensure that the power system is turned off and the battery pack is turned off;
3. All power-saving cables must have corresponding insulation measures, and it is strictly forbidden to expose the power cord;
4. Ensure that the battery and the power system are reliably grounded during installation.

### 9.3 Installation Notes

1. When begin to install the battery system, you should pay attention to the following matters:
2. Installation space and load bearing. Make sure that there are sufficient fixed components to install the battery system, and to ensure that the battery mounting bracket or the cabinet be strong enough to bear the weight.
3. Cable specifications. To ensure that the use of the connection of the power supply line can meet the maximum current requirements of equipment operation.
4. Project layout. Ensure the whole construction process of power equipment, batteries and other reasonable layout.
5. Wiring layout, Ensure that the wiring reasonable, orderly; and consider the moisture-proof, corrosion prevention.
6. The whole installation process should wear anti-static wristband.
7. The installation site should be at least two or more peoples to operate.
8. Please ensure the installation site safe before installation.

### 9.4 Installation Steps

1. Select a suitable solid wall with a thickness greater than 150mm;
2. Refer to the fixing distance of the mounting bracket bolts, and mark the hole position on the wall;
3. Drill 4 holes according to the hole position, the depth is  $\geq 80$ mm;
4. Mount the M8 expansion bolts in the upper holes and screw on the nuts;
5. With the battery upright, suspend the battery from the expansion screw.

Step No.	Name	Definition
1	Turn off power supply	The system should be powered off, to ensure that there is no electric in installation process
2	Mechanical installation	1. Mounting lugs installation 2. Battery fixed installation
3	Electrical installation	1. Grounding cable 2. Power cable installation 3. Connecting equipment installation 4. Communication cable installation
4	Electrical commissioning	Power system commissioning

### Step1.Interruption Of Power Supply

Before installation, please ensure the battery is powered off, at the same time, shutdown the equipment which need to connect to the battery.

### Step2.Operational Process

- 1.Install expansion screws. Before installing the battery, secure the expansion screws to the wall.
- 2.Secure the battery. Secure the battery module to the expansion screws to ensure that the battery pack is securely installed.
- 3.Expansion bolt installation diagram.

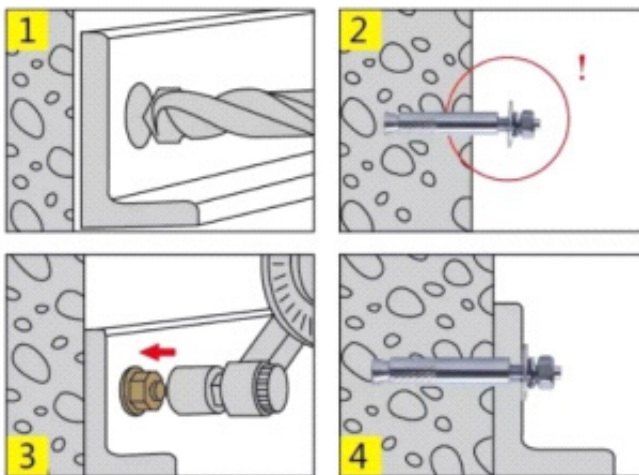

### NOTICE:

1. In order to avoid electric shock or other injuries, check whether the existing electronic plumbing installation is compliant before drilling.
2. The battery is heavy, please handle it with care, so as not to damage the product or injure the installer.

## 9.5 Electrical Connection

### ◆Single Unit Wiring:

Step 1. Connect the positive and negative terminals of the battery to the positive and negative terminals of the inverter using the power cable.

Step 2. Complete the battery's grounding connection by using the ground wire.

Step 3. Connect the RS485A (or CAN) port of the battery to the RS485 (or CAN) communication port of the inverter using the communication cable.

Step 4. If used as a single unit, set the ADS dip switch to 1. Refer to section for dip switch rules.

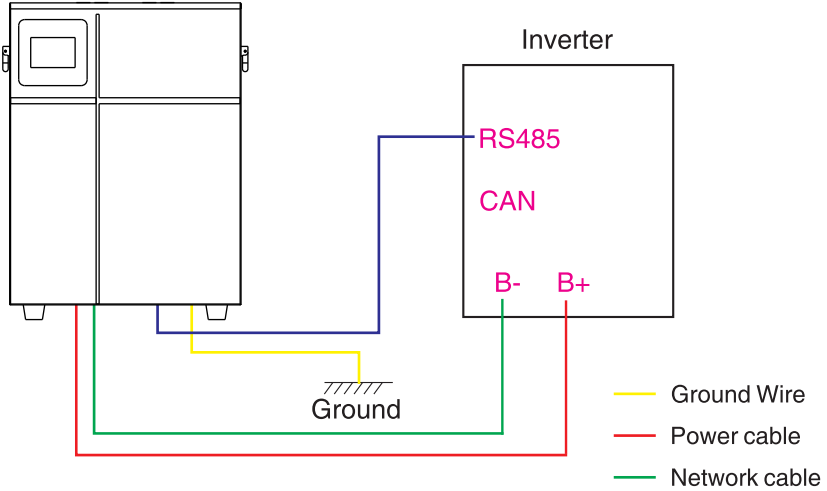

### ◆Parallel Wiring:

Step 1. If multiple batteries are used in parallel, manually press the low-voltage switch (ON/OFF) first. Use a multimeter to check if the voltage of each battery is consistent. If consistent, turn off the batteries and proceed with cable connections, as shown in the schematic diagram (using two batteries in parallel as an example).

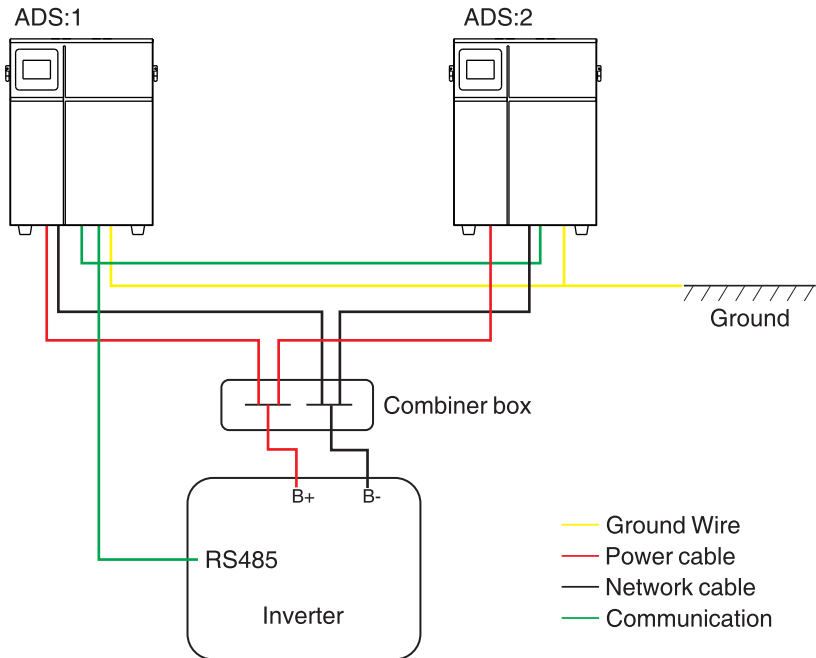

Step 2. Connect the positive terminal of the battery using the power cable, and then connect the negative terminal of the battery using the power cable.

Step 3. Connect the RS485B communication interface of adjacent batteries with communication cables (RS485B battery parallel ports have the same functionality and are not distinguished).

Step 4. Connect the ground cable to the ground point of all batteries. There is a ground symbol in the lower right corner of the battery to connect the ground terminal to this point.

Step 5. Use a standard Category 6 cable. Connect one end to the RS485A (or CAN) communication interface of the battery and the other end to the RS485 (or CAN) interface of the inverter (Note: the pin definition of the inverter communication should match that of the battery; refer to section for battery-to-inverter pin definitions).

Step 6. Connect the positive terminal (+) of the first battery to the positive terminal interface of the inverter using the power cable. Then, connect the negative terminal (-) of the last battery to the negative terminal interface of the inverter using the power cable.

#### NOTICE:

1. The battery directly connected to the inverter via the communication cable is defined as the host. The host dip switch is set to 1 and needs to be switched before powering on.
2. Define dip switches for other batteries sequentially from 2 to 15. Avoid duplicating dip switch settings to 1.

## 10. Debugging

### 10.1 RS485 & CAN Port Definition

1. Definition of RS485A port (default baud rate 9600bps) for communication between the battery and the inverter.

Orange&white / orange / Green&white / blue / Blue&white / green / Brown&white / brown

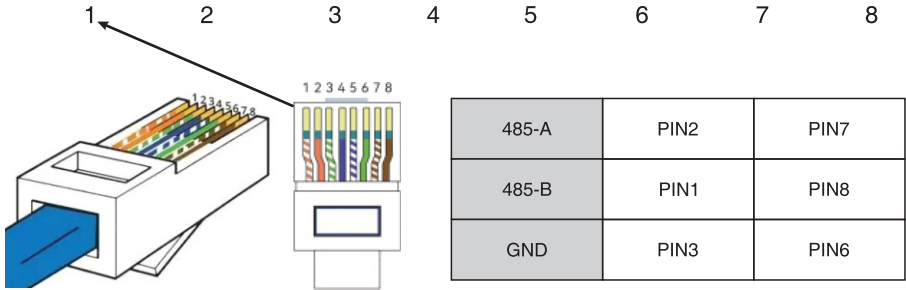

**NOTICE:**

The default RS485 protocol for the battery is set to Pylontech RS485 (V3.5) protocol. if compatibility with other inverters is needed, it is necessary to communicate through RS232 with the host computer to change the default protocol.

2. Definition of CAN port (default baud rate is 500K) for communication between the battery and the inverter.

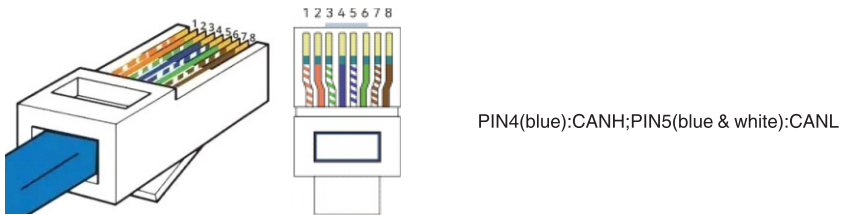

**NOTICE:**

The battery is factory-set with the default CAN protocol, defaulting to Pylontech CAN (V1.2) protocol, If compatibility with other inverters is required, it is necessary to communicate through RS232 with the upper computer to change the default protocol.

**Tip:**

For battery and inverter communication, choose either RS485 or CAN.

# 11.Upper Computer Software Operation Guide

Modifying Battery Parameters and Selecting Inverter Protocol via RS232 Upper Computer.

## 11.1Tools

- Computer
- USB to RS232 Cable
- Monitoring Software

## 11.2Operating Steps

- 1.Connect the computer to the battery using a USB to RS232 cable. Plug the USB end into the computer's USB port and the other end into the battery's RS232 port.
- 2.Download and unzip the software package on the computer.
- 3.Open the extracted folder and select the application, as shown below:

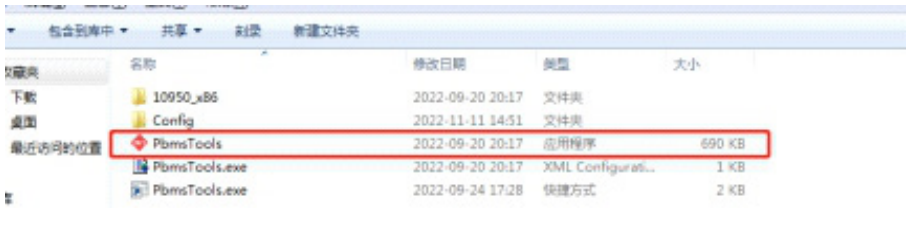

- 4.Double-click the above icon to enter the monitoring interface, as shown below:

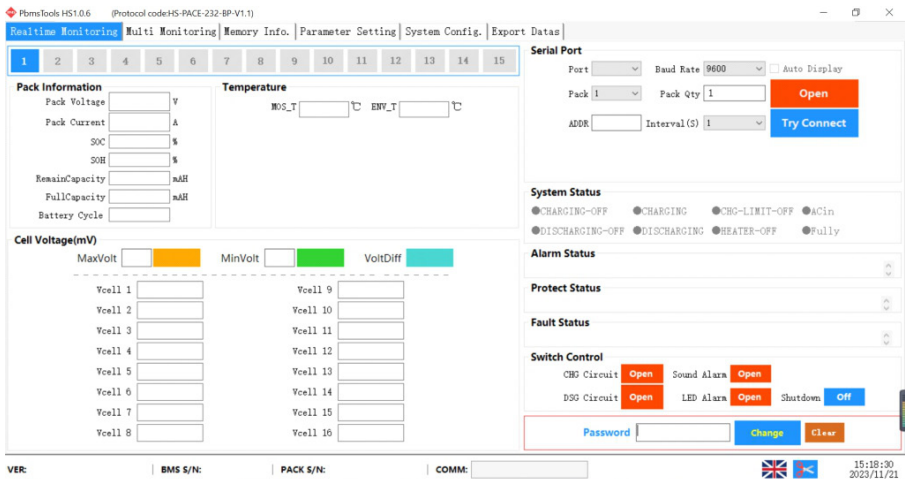

5. After entering the monitoring interface, click on the top right to open the serial port. Once communication with the battery is established, the left side will display real-time battery information, and the status bar in the lower right will turn green.

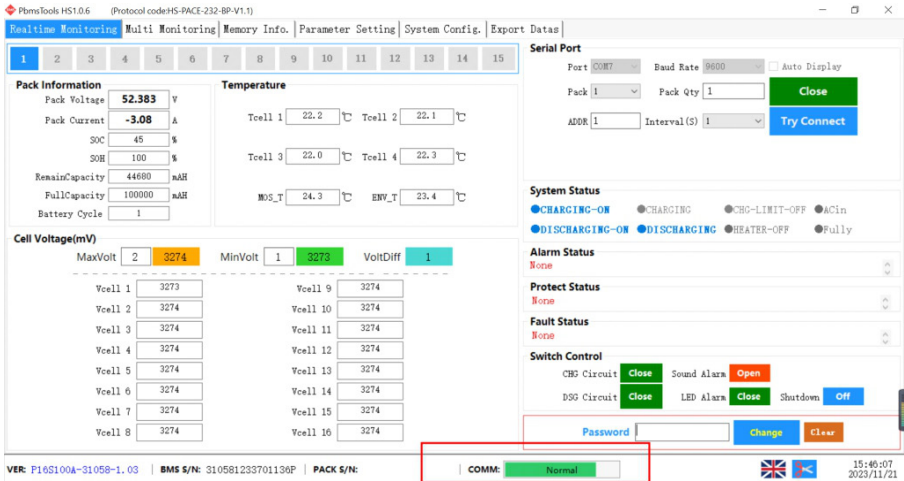

6. After successful communication, enter the password "123456" in the lower right password status bar. Upon correct input, the status bar will turn green.

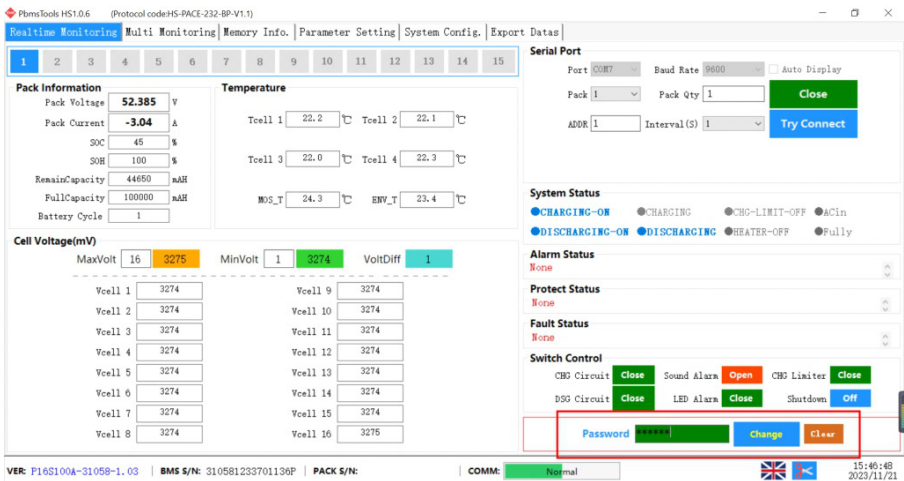

7. Left-click on "System Config," as shown below:

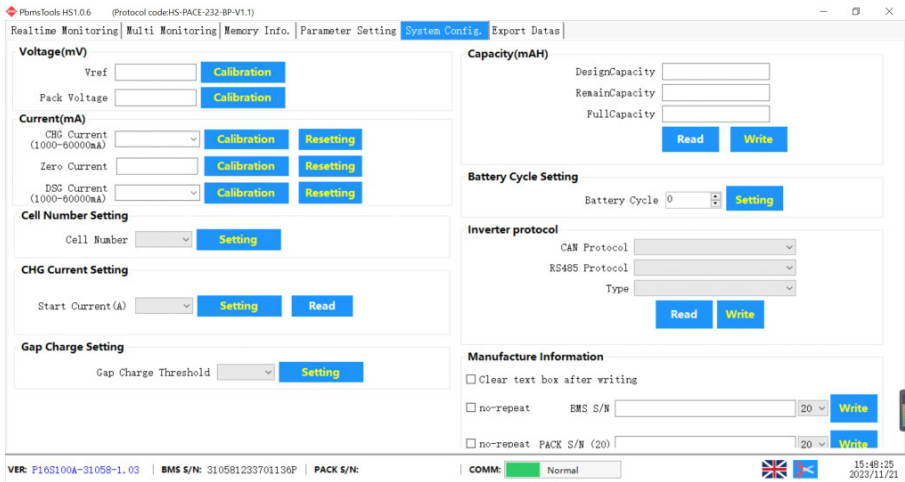



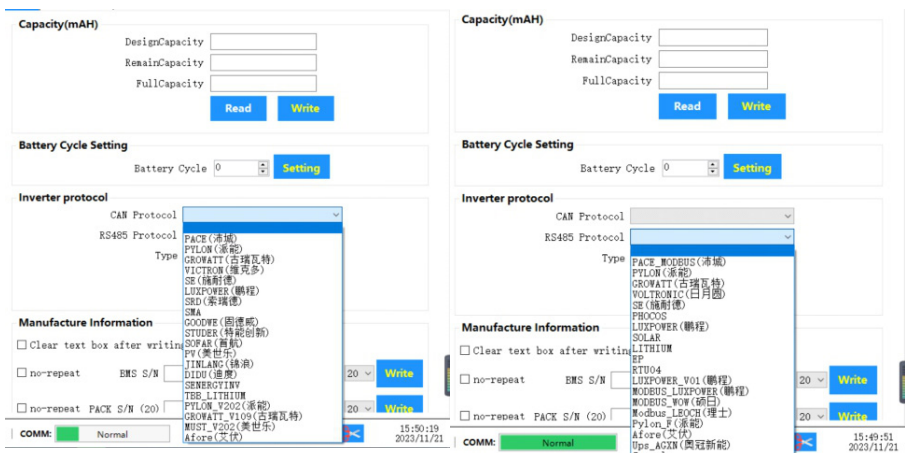













8. In the middle-right part of the display interface (Inverter Protocol), click "Read" to check if the battery matches the actual inverter brand. If not, click on the CAN or 485 protocol and choose the protocol that matches the inverter, as shown below:



9. After selecting the protocol, click the "Write" button. If the write fails, it indicates that the BMS does not include this inverter protocol, and a program upgrade is required. If the write is successful, click "Read" again to verify the selected protocol.

## 12.ADS Dip Switch Definitions

Address	DIP Switch Position				Illustration
	#1	#2	#3	#4	
0	OFF	OFF	OFF	OFF	 ON OFF
1	ON	OFF	OFF	OFF	 ON OFF
2	OFF	ON	OFF	OFF	 ON OFF
3	ON	ON	OFF	OFF	 ON OFF
4	OFF	OFF	ON	OFF	 ON OFF
5	ON	OFF	ON	OFF	 ON OFF
6	OFF	ON	ON	OFF	 ON OFF
7	ON	ON	ON	OFF	 ON OFF
8	OFF	OFF	OFF	ON	 ON OFF
9	ON	OFF	OFF	ON	 ON OFF
10	OFF	ON	OFF	ON	 ON OFF
11	ON	ON	OFF	ON	 ON OFF
12	OFF	OFF	ON	ON	 ON OFF
13	ON	OFF	ON	ON	 ON OFF
14	OFF	ON	ON	ON	 ON OFF
15	ON	ON	ON	ON	 ON OFF

### 13. Battery Parallel Connection Dip Switch Diagram

1 Battery	2 Battery	3 Battery	4 Battery	5 Battery	6 Battery	7 Battery	8 Battery
9 Battery	10 Battery	11 Battery	12 Battery	13 Battery	14 Battery	15 Battery	

## 14. Power-on Sequence

After the completion of the connections between the inverter, battery, and mains power, start each battery one by one. Then, turn on the inverter. After the battery startup, check if the communication between the inverter and the battery is normal. If the battery data is successfully uploaded to the inverter, it indicates successful communication between the inverter and the battery.

## 15. Common Issues And Solutions

No.	Fault Symptoms	Cause Analysis	Solution
1	No DC Output	Battery Voltage Too Low, Protection Activated	Startup after Charging Activation
2	Short Power Supply Time	Insufficient Battery Capacity or Failure to Reach Full Charge	Confirm Maintenance or Replace Battery
3	Battery Cannot Reach Full Charge	DC Voltage Output from Power System Lower than Minimum Charging Voltage	Adjust Device's DC Output Voltage to Suitable Charging Voltage for Battery
4	Unstable Battery Output Voltage with Significant Fluctuations	Interference with Management System Operation	Restart the System
5	Temperature Monitoring Too Low	Damage to Temperature-Sensing Crystal Head	Replace the Collection Line with a Temperature-Sensing Crystal Head
6	Unable to Charge	Single Cell Protection Activated upon Full Battery Charge	Discharge Protection Removal
7	MOS temperature abnormal	MOS tube damaged	Replace BMS
8	Discharge overcurrent protection	Inverter power exceeds limit	Match the number of batteries according to the inverter power value

## 16. Inverter Matching Information

Inverter Brand	LOGO	Communication Method	Inverter Communication Pin	Battery Communication Pin	Remarks
BEVE POWER		RS485	PIN2:RS485A PIN1:RS485B	PIN2/7:RS485A PIN1/8:RS485B	Default Battery Protocol Matching
Voltronic Power		RS485	PIN5:RS485A PIN3:RS485B	PIN2/7:RS485A PIN1/8:RS485B	1.Default Battery Protocol Matching 2.Customized Network Cable
VICTRON		CAN	PIN7:CANH PIN8:CANL	PIN4:CANH PIN5:CANL	1.Battery Protocol Change 2.Customized Network Cable
Growatt		RS485	PIN2:RS485A PIN1:RS485B	PIN2/7:RS485A PIN1/8:RS485B	1.Default Battery Protocol Matching 2.inverter Protocol Setting Option 2
		CAN	PIN4:CANH PIN5:CANL	PIN4:CANH PIN5:CANL	
PYLONTECH		RS485	PIN7:RS485A PIN8:RS485B	PIN2/7:RS485A PIN1/8:RS485B	Default Battery Protocol Matching
GOODWE		CAN	PIN4:CANH PIN5:CANL	PIN4:CANH PIN5:CANL	Default Battery Protocol Matching
LUXPOWER		RS485	PIN2:RS485A PIN1:RS485B	PIN2/7:RS485A PIN1/8:RS485B	1.Battery Protocol Change 2.Customized Network Cable
SOFAR		CAN	PIN1:CANH PIN2:CANL	PIN4:CANH PIN5:CANL	1.Battery Protocol Change 2.Customized Network Cable
SRNE		RS485	PIN7:RS485A PIN8:RS485B	PIN2/7:RS485A PIN1/8:RS485B	1.Default Battery Protocol Matching 2.Inverter Protocol Setting PyL
Deye		RS485	PIN7:RS485A PIN8:RS485B	PIN2/7:RS485A PIN1/8:RS485B	Default Battery Protocol Matching
		CAN	PIN4:CANH PIN5:CANL	PIN4:CANH PIN5:CANL	
MEGAREVO		CAN	PIN4:CANH PIN5:CANL	PIN4:CANH PIN5:CANL	Default Battery Protocol Matching
MUST		CAN	PIN6:CANH PIN5:CANL	PIN4:CANH PIN5:CANL	1.Battery Protocol Change 2.Customized Network Cable
SMA		CAN	PIN4:CANH PIN5:CANL	PIN4:CANH PIN5:CAN	Battery Protocol Change
SOLA X		RS485	PIN2:RS485A PIN1:RS485B	PIN2/7:RS485A PIN1/8:RS485B	Default Battery Protocol Matching
		CAN	PIN4:CANH PIN5:CANL	PIN4:CANH PIN5:CANL	

## 17.Maintenance

- 1.Do not immerse the battery in water. When not in use, store it in a cool and dry environment.
- 2.Do not throw the battery into the fire or heat it externally to avoid explosion or other hazards.
- 3.Do not invert the positive and negative poles of the battery, Never connect the battery directly to a power outlet, and prohibit short-circuiting the positive and negative poles.
4. Do not mix batteries from different manufacturers, different kinds, types, or different ages.
- 5.Do not use batteries that show signs of heating, swelling, deformation, or leakage in charging or discharging devices.
- 6.Prohibit piercing the battery with nails or other sharp objects, as well as throwing, stepping on, hitting, or impacting the battery.
- 7.Prohibit disassembling or dismantling the battery and its components. Any damage caused by unauthorized disassembly or repair will not be the responsibility of our company.
- 8.The battery undergoes strict inspection before leaving the factory. If customers find signs of heating, swelling, or unusual odors, do not use it and return it to the factory immediately.
- 9.For long-term storage, to ensure optimal battery performance, perform a charge-discharge cycle every three months and ensure a storage charge of 40%~60%, Prevent the battery from discharging completely
- 10.Use the battery within the specified temperature range as stated in the specification.
- 11.Follow the specified power-up sequence for both the battery and the inverter.
- 12.The recommended load power for the battery should not exceed the maximum continuous discharge current of the battery.

### NOTE:

In case of specific technical issues or situations not mentioned above, please contact technical support promptly.



## FRONUS SOLAR ENERGY (WASIQ TRADERS).

**UAN:** +92 42 111 111 140

**Email:** INFO@FRONUS.COM

**Website:** WWW.FRONUS.COM

**Address:** Fronus House, Plot# 64 & 65, Maulana Shaukat Ali Rd, Block E  
Phase 1 Johar Town, Lahore, 54782



320101100701